

verilux[®]
The Healthy Lighting Company[®] Est. 1956

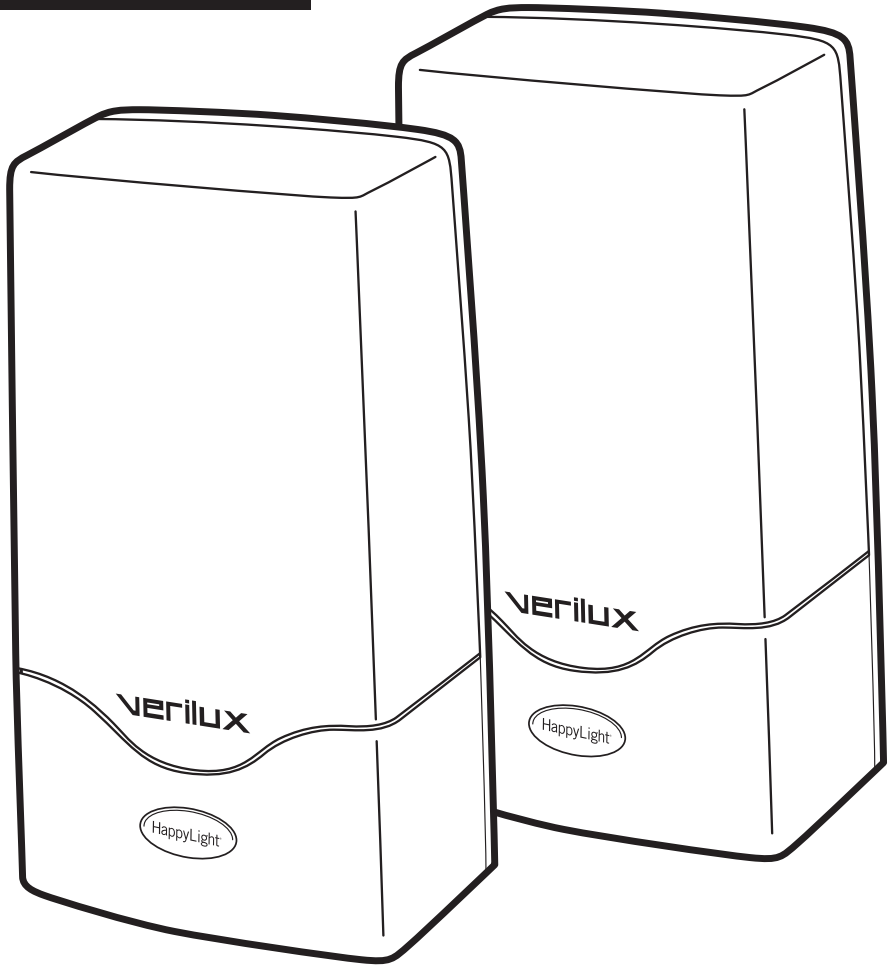

HappyLight[®] | twin pack

Compact Energy Lamp

VTCP01



Dear Customer,

Thank you for purchasing the Verilux HappyLight® Compact Energy Lamp Twin Pack. You have received an innovative and quality manufactured product, backed by a one-year limited warranty.

This product brings Natural Spectrum® Daylight into your home or office. Many other healthy lighting products are available through our catalog and online. Visit us on the web at www.verilux.com to request a free catalog and learn more about all our quality Verilux products, or call our toll-free number 1-800-454-4408.

As a Verilux customer, your satisfaction means everything to us. We look forward to serving you now and in the future.

Have a Bright Day!

Nicholas Harmon
President, Verilux, Inc.

Contents

Warnings and Precautions	4
Features.	5
Operation.	6
Selecting a Location	6
Instructions for Use	6
Recommended Usage	7
Bulb Removal and Replacement.	8
Troubleshooting.	10
Care and Cleaning.	10
Technical Specifications	11
Warranty	12

Warnings and Precautions

- Please read the following precautions before using these lamps.
- These lamps are for indoor use only.
- Do not place these lamps near any heat sources such as radiators, heat registers, stoves or other apparatus (including amplifiers) that produce heat.
- Do not block any ventilation openings in the rear of the lamps.
- Do not defeat the safety purpose of the polarized plug. A polarized plug has two blades with one wider than the other. The wider blade is provided for your safety. If the provided plug does not fit in your outlet, consult an electrician for replacement of the obsolete outlet.
- Protect the power cord from being walked on or pinched, particularly at plugs, convenience receptacles and the point where the power cord exits the lamp.
- Unplug these lamps during lightning storms or when unused for long periods.
- If these lamps have been damaged in any way, for example, the power supply cord or plug has been damaged, liquid has been spilled or objects have fallen onto the lamp, the lamp has been exposed to rain or moisture, the lamp does not operate normally or has been dropped, it should not be operated. There are no user serviceable parts in this lamp.
- Do not use with power supply voltage other than 120V AC.
- Avoid placing the lamps in areas that are dusty, humid/moist, lack ventilation or are subject to constant vibration.
- These lamps are not for use with light dimmers, timers, motion detectors, voltage transformers or extension cords.
- Close supervision is recommended when these lamps are used by or near children, or others who may not understand the need for these precautions.
- Do not leave the lamps unattended during use.
- Do not use a lubricating agent in bulb assembly.

Do not use this product if:

- You are hypersensitive to light and/or experience eye discomfort.
- You are currently taking any medication that might increase your sensitivity to light.
- You feel uncomfortable after using the product.
- You have a history of eye disease including, but not limited to, cataracts or macular degeneration.

Warnings and Precautions — continued



WARNING: TO REDUCE THE RISK OF FIRE, ELECTRIC SHOCK OR PERSONAL INJURY:

- Turn off/unplug and allow to cool before replacing bulb or cleaning.
- Light bulbs get hot quickly! Do not touch the bulb while the lamp is on.
- Do not look directly at the lighted bulb without the diffuser being in place.
- Do not operate lamps in close proximity to flammable or combustible vapors, such as aerosol spray products, or where oxygen is being administered.
- Use only the type of bulb and maximum wattage indicated by Verilux®.
- Never cover the lamp or place anything on top of it when it is in operation.
- To prevent risk of shock or personal injury when cleaning lamp, make sure you have turned off and unplugged the lamp, and allowed sufficient time for the bulb to cool.

SAVE THESE INSTRUCTIONS

Features

Your new Verilux HappyLight® Compact Energy Lamp Twin Pack:

- Delivers Natural Spectrum® Daylight to your home, office, dorm room or apartment with no dangerous ultraviolet (UV) wavelengths.
- Has up to 2,500 LUX of bright Natural Spectrum light to lift spirits, sharpen concentration and improve energy levels.
- Activates your body's own energy enhancers to make you more alert and productive.
- Is designed with a compact shape and small footprint to make it easy to place in a convenient location.
- Has an energy efficient, cool burning 26 Watt 10,000 hour bulb.
- Features a convenient on-off power switch on cord.
- Includes best-in-class power system with electronic ballast and patented Flicker Elimination Technology® to assure no-buzz operation and instant-on, flicker-free illumination.

Operation

Selecting a Location

- Place your Verilux® HappyLight® Compact Energy Lamps on a table or other flat surface.
- For best performance, place the HappyLight as close as 6 inches, but within 18 inches from your face.

Note: Avoid placing this lamp in areas that are exposed to direct sunlight or close to heat-radiating products such as heaters. Do not place the lamp on the top of appliances that radiate heat.



WARNING: DO NOT BLOCK VENTS

Vents are necessary for proper function of the electronic ballast; blocking them may cause overheating of the electronics and increase risk of fire.

Instructions for Use

Use consists of sitting close to the HappyLight® Compact Energy Lamp with your eyes open. While staying oriented toward the light, feel free to engage in other activities such as reading, writing, hobbies and crafts, sewing, needlepoint, applying make-up, painting or working at your computer or desk.

1. Turn on the lamp and allow a few minutes for the bulb to achieve full brightness.
2. The HappyLight Compact Energy Lamp should be positioned as close as 6 inches, but within 18 inches from your face, and should be slightly offset from center (see diagram).
Note: It is not necessary to stare directly at the light.

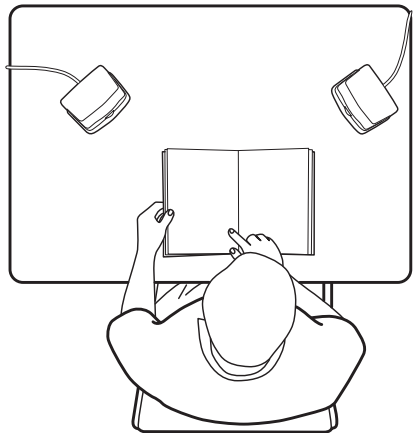

The light from the HappyLight Compact Energy Lamp must be directed at your eyes; therefore, your eyes must be open to achieve the full benefit. *Note: Tinted glasses reduce the amount of light reaching your eyes.*

When you are feeling sluggish and lethargic, spend more time with the light, sit closer to the light or add more lighting devices to increase the intensity. If you experience edginess, or are over stimulated, move the light further away or reduce usage time.

Minimum Recommended Usage

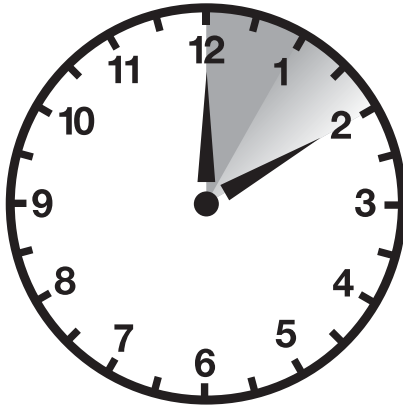

**1 hour
to
2 hours***

Researchers at the National Institute of Health demonstrated that white light, in a range of 2,500 to 10,000 LUX (a measurement of light intensity), helped to reverse the symptoms of “Winter Blues”.

Different exposure strategies work for different people. We all have different reactions to our environment. It is important to establish a distance and schedule that is comfortable for you. We recommend you use the light regularly and at about the same time each day. It is not necessary to sit in front of the lamp continuously. You can divide the time into several mini sessions. Continue to use the HappyLight® daily to feel an improvement in your mood and activity level.

When you are feeling sluggish and lethargic, spend more time with the light, sit closer to the light or add more lighting devices to increase the intensity. If you feel a sort of edginess, as though you have drunk too much coffee, then it may be time to turn the unit off.

*2,500 LUX at 6". Recommended exposure time is a function of output and distance. Individual results may vary.

Bulb Removal and Replacement

Your HappyLights® use a bulb manufactured only by Verilux®. To order a replacement bulb, please call Verilux, toll-free, at 1-800-454-4408.

To Replace the Bulb:

1. Unplug the lamp from power outlet.
2. To access the bulb, remove the plastic diffuser by pressing the tabs (D) and lifting out the diffuser.
3. Firmly hold the bulb base (B) (do not hold the glass portion of the bulb) and turn bulb in a slight counter-clockwise direction until it releases from the socket.

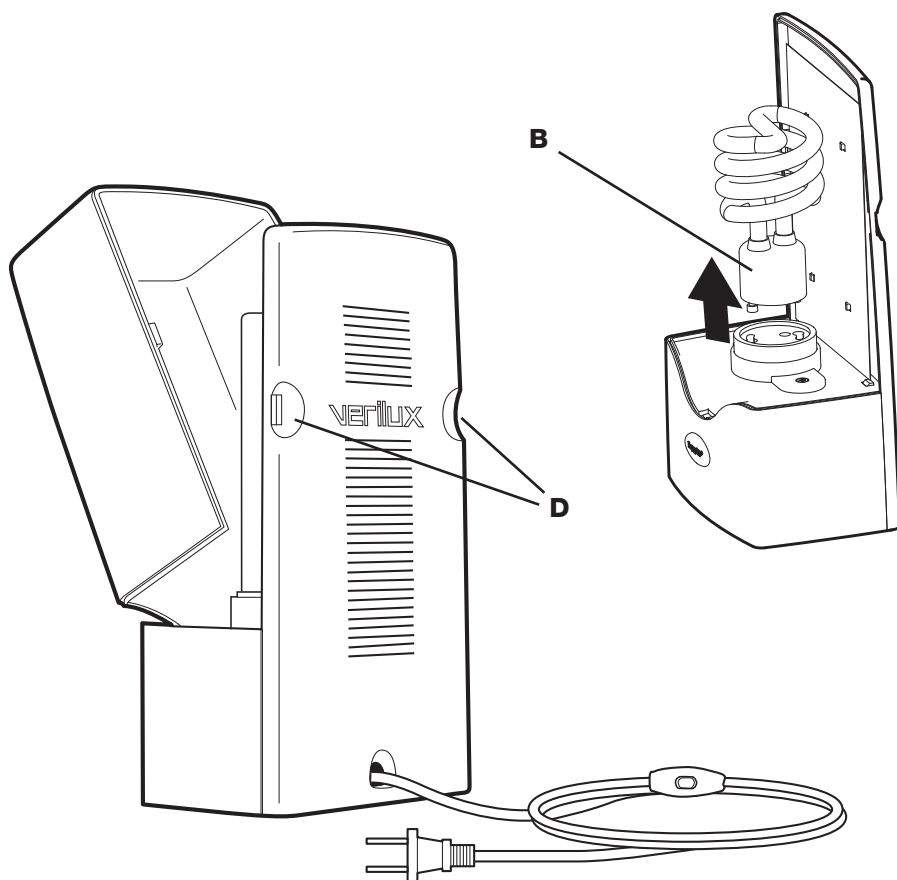

Bulb Removal and Replacement — continued

Re-installing Bulb and Plastic Diffuser

1. To install the bulb, insert bulb into lamp by firmly holding bulb base and pushing down and rotating slightly in a clockwise direction to seat properly.
2. Attach the diffuser to the lamp body by first inserting the tab located at the bottom of the diffuser (A) into the opening of the lamp base (B).
3. Insert one diffuser corner at a time into the side track and gently down into place into the bottom track.
4. Snap side tab into place on side slot. Entire side of diffuser should be seated into the track. Repeat for other side of diffuser. **Note:** Alignment of diffuser corner into side track.
5. Firmly push diffuser down until **Tab A** snaps into place. Align top of lens in top track as necessary.

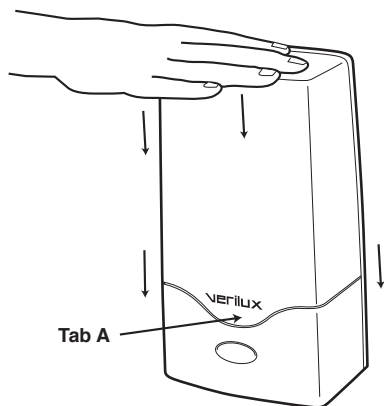
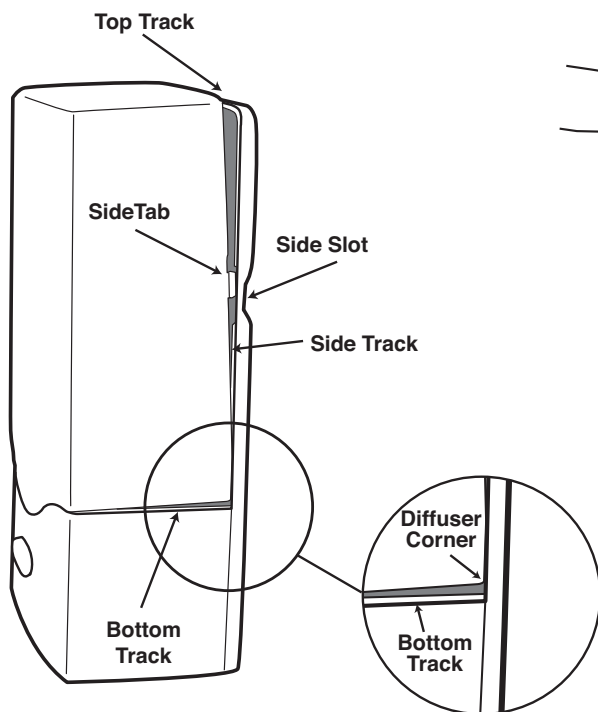
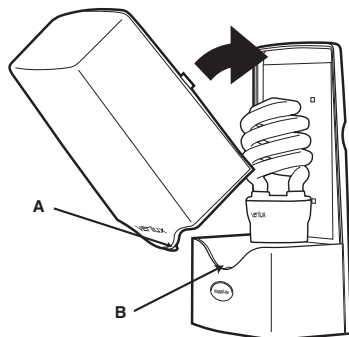

Troubleshooting

Before requesting service on your Verilux® lamp, please read the following:

- Make sure all power connectors, cords and plugs are inserted fully and securely.
- Be sure the bulb is securely seated in the socket (see page 9).
- Make sure there is power to the wall outlet or try another outlet – one that is not connected to a dimmer.

PROBLEM	CHECK	SOLUTION
Light Won't Come On	Has the plug come loose?	Insert plug securely into wall outlet.
	Is the bulb old?	Check bulb for blackening/darkening at bottom of spiral where it joins the base (an indicator of bulb life) and replace bulb.
	Is the bulb connected securely into socket?	Be sure the bulb is securely seated into socket, repeat the bulb installation process.
Blackening/Darkening at Ends of Bulb	Is the bulb new?	Sometimes when a new bulb is turned on for the first time the tube will darken, but this will fade after a few minutes.
	Is the bulb old?	With older bulbs, darkening of the tube indicates end of bulb life (this doesn't affect operation except to reduce the amount of light available since the phosphor in that area has become inactive). Bulb replacement is recommended.
Light Flickers	Has the plug come loose?	Insert plug securely into wall outlet.
	Is the bulb connected securely to the socket?	Be sure the bulb is securely seated into the socket, repeat the bulb installation process. CAUTION: DISCONNECT LAMP FROM OUTLET PRIOR TO REPEATING THE BULB INSTALLATION PROCESS.
	Is the lamp connected to a dimmer switch?	Connect lamp plug only to wall outlet without dimmer switch.

Care and Cleaning

Your Verilux lamps are made from high quality materials that will last for many years with a minimum of care.

Clean only with a soft dry cloth – DO NOT USE SOLVENTS OR CLEANERS CONTAINING ABRASIVES OR AMMONIA.



WARNING: To prevent risk of shock or personal injury when cleaning lamp, make sure you have turned off and unplugged the lamp, and allow sufficient time for the bulb to cool.

Technical Specifications

HappyLight® Compact Energy Lamp Twin Pack

Environment

Operating Temperature: 15°C to 35°C; 56°F to 95°F

Storage Temperature: 0°C to 40°C; 32°F to 104°F

Relative Humidity: 5% to 95% non-condensing

Bulb

Replacement bulb: 26 Watt 10,000 hour bulb (replace with Verilux brand only, Model number CFS26GU24VLX)

Power

Input Power: AC 120V~60Hz

UL Listed

One Year Limited Warranty

ATTENTION! ONCE OPENED, PLEASE **DO NOT** RETURN THIS PRODUCT TO THE STORE WHERE IT WAS PURCHASED FOR REPAIR OR REPLACEMENT!

Many questions may be answered by visiting www.verilux.com, or you may call our Customer Service Department at 800-786-6850 during normal business hours.

This limited warranty is provided by: Verilux, Inc., 340 Mad River Park, Waitsfield, VT 05673

Verilux warrants this product to be free from defects in material and workmanship for a period of one year from the date of the original retail purchase from Verilux or an authorized Verilux distributor. **Proof of purchase is required for all warranty claims.** During the limited warranty period, Verilux, Inc. will, at its option, repair or replace defective parts of this product, at no charge to the customer, subject to the following limitations: This limited warranty does not include any postage, freight, handling, insurance or delivery fees. This warranty does not cover damage, defect or failure caused by or resulting from accident, external destruction, alteration, modification, abuse, misuse or misapplication of this product.

This warranty does not cover damage to the product resulting from return shipping or handling. The use of shipping insurance is recommended to help protect your product.

Return Authorization is required for all returns. To obtain a Return Authorization, please contact the Verilux Customer Service Department at 800-786-6850.

If, during the first year of ownership, this product fails to operate properly, it should be returned as specified at www.verilux.com/warrantyreplacement or as instructed by a Verilux customer service representative at 800-786-6850.

Note: *Verilux recommends using a quality surge suppressor on all electronics equipment. Voltage variations and spikes can damage electronic components in any system. A quality suppressor can eliminate the vast majority of failures attributed to surges and may be purchased at electronics stores.*

Due to ongoing improvements, actual product may have slight variations from the product described in this manual.

Please visit our website at www.verilux.com or call our Customer Service Department at

1-800-786-6850

Representatives are available Monday — Friday, 9am — 5pm EST

verilux®

340 Mad River Park, Waitsfield, VT 05673