

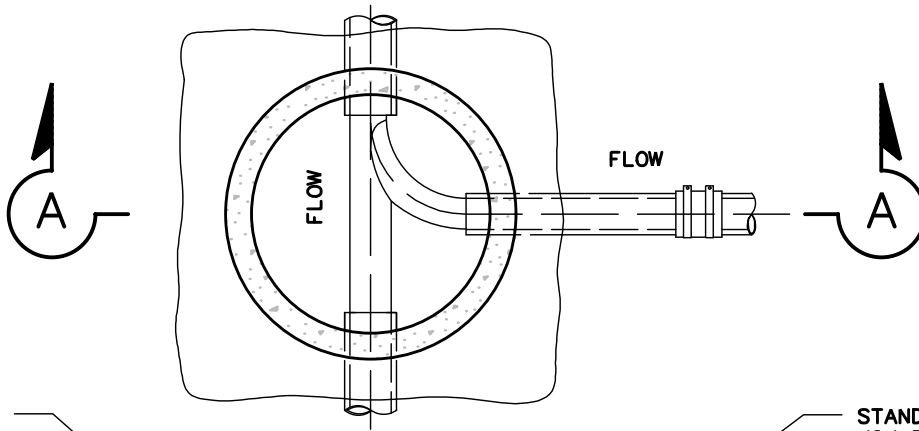

COUNTY SANITATION DISTRICT NO. 2-3

SEE CITY/COUNTY TRENCH
DETAIL FOR BACKFILL
REQUIREMENTS AND
SEE DISTRICTS STANDARD
TRENCH DETAIL
FOR MINIMUM BACKFILL
REQUIREMENTS



PLAN VIEW

MARKER POST. 4" SCH40 STEEL PIPE 6' LONG FILLED WITH CONCRETE

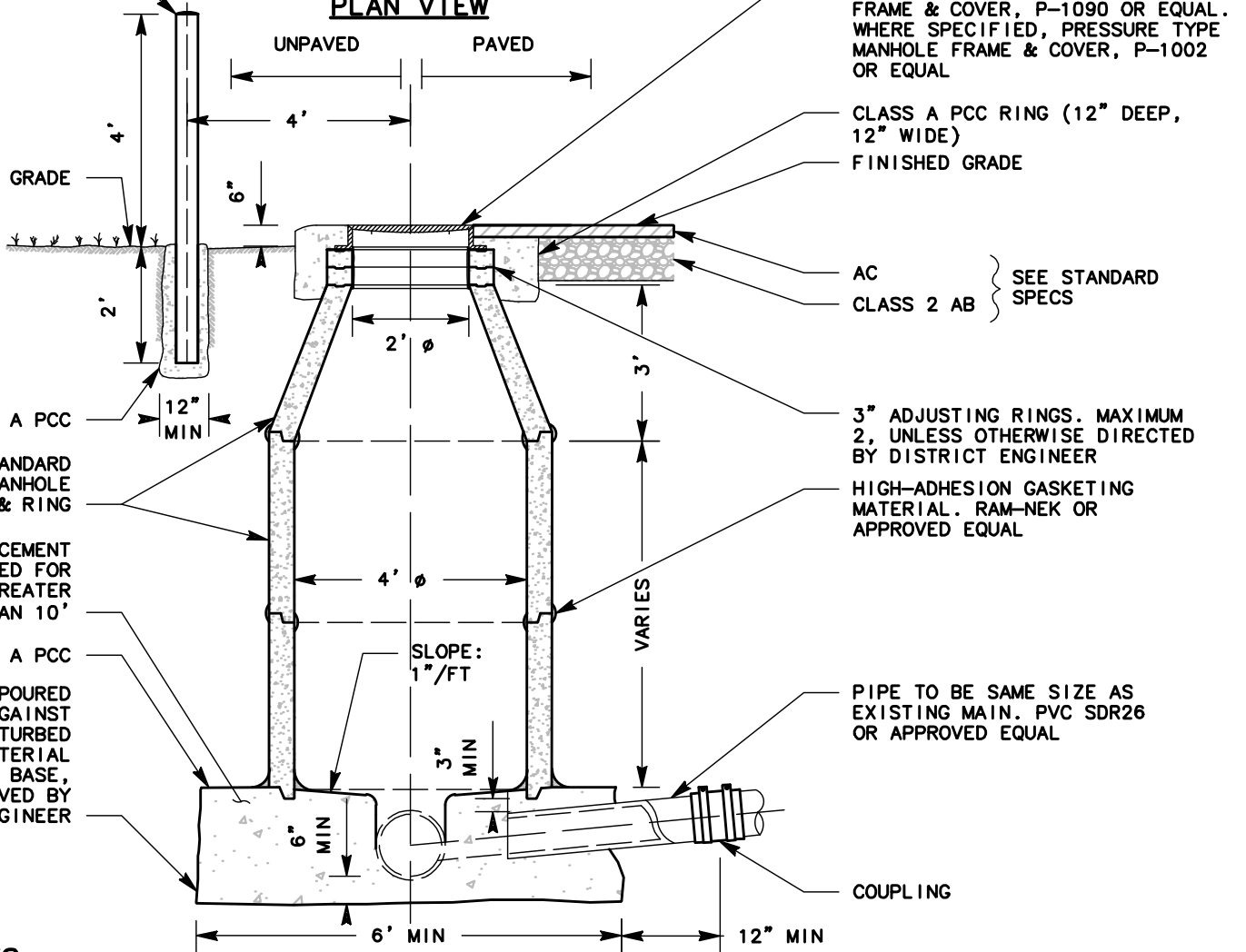

SECTION A-A

NOTES:

1. COUPLING BAND SHALL BE MISSION Banded STAINLESS STEEL "ARC SHIELD", FERNCO STAINLESS STEEL "SHEAR RING", OR APPROVED EQUAL. COUPLING BAND IS REQUIRED FOR ALL CONNECTIONS TO THE MANHOLE.
2. ALL CONCRETE TO BE SIX (6) SACK.
3. ALL GROUT SHALL CONTAIN "HYDROPEL" EXCEPT WHEN DIRECTED OTHERWISE BY DISTRICT ENGINEER.

STANDARD MANHOLE

DETAIL **2**

DR. BY:	DATE:	CK. BY:	DATE:
ED	06/01/2020	FQ	06/01/2020

APPROVED. BY:	DATE:
<i>REC</i>	06/01/2020

DATE:	06/01/2020
-------	------------