



Counterbalanced Cushion Tire Forklift 5,000 lbs. Capacity

KBG25C
Series 6010 LPG Forklift Trucks



Technical Data

November 2017

	POS	ITEM DESCRIPTION	UNIT		
Specification	1.1	Manufacturer		KION BAOLI	
	1.2	Model designation		KBG25C	
	1.3	Power unit		LPG	
	1.4	Operation		Rider Seated	
	1.5	Load capacity	Q	5000 lbs	2268 kg
	1.6	Load center	c	24 in	600 mm
	1.8	Axle center to fork face	x	17.3	440 mm
	1.9	Wheelbase	y	55.1 in	1400 mm
	Weight	2.1	Service weight		8950 lbs
2.2		Axle weight with load, front		12522 lbs	5680 kg
2.2.1		Axle weight with load, rear		1455 lbs	660 kg
2.3		Axle weight without load, front		3527 lbs	1600 kg
2.3.1		Axle weight without load, rear		5423 lbs	2460 kg
Wheels and Tires	3.1	Tire: SE=(superelastic), P=(pneumatic), C=(cushion)	-	CU/CU	
	3.2	Tire size, front	-	21 x 7-15	
	3.3	Tire size, rear	-	16 x 6-10.5	
	3.5	Wheels, number front/rear (X=drive)	-	2X / 2	
	3.6	Track width, front	b ₁₀	35 in	890 mm
	3.7	Track width, rear	b ₁₁	35.6 in	905 mm
	Dimensions and Overall Sizes	4.1	Mast tilt, forward / backward	/ (°)	6° / 5°
4.2		Height of mast, lowered	h ₁	86 in	2185 mm
4.3		Free lift	h ₂	45 in	1140 mm
4.4		Lift	h ₃	186 in	4724 mm
4.5		Height of mast, extended	h ₄	225.5 in	5730 mm
4.7		Height of overhead guard (cabin)	h ₆	83.3 in	2115 mm
4.8		Height of drive seat	h ₇	46.1 in	1170 mm
4.12		Tow coupling height	h ₁₀	14.1 in	360 mm
4.19		Overall length	l ₁	135.4 in	3440 mm
4.20		Length to fork face	l ₂	93.3 in	2370 mm
4.21		Overall width	b ₁ / b ₂	42 in	1066 mm
4.22		Fork dimensions SxExL	SxExL	1.6x4.7x42 in	40x120x1070 mm
4.23		Fork carriage class		2	
4.24		Width of fork carriage	b ₃	37.8 in	960 mm
4.31		Ground clearance with load, mast	m ₁	3.3 in	85 mm
4.32		Ground clearance with load, center of wheelbase	m ₂	4.6 in	118 mm
4.33		Aisle width, (1000 x 1200 pallet, a = 200 mm)	Ast	155.8 in	3957 mm
4.34		Aisle width, (800 x 1200 pallet, a = 200 mm)	Ast	97.8 in	2483 mm
4.35		Turning radius	Wa	80.4 in	2043 mm
4.36		Minimum pivoting point distance (internal turning radius)	b ₁₃	23.1 in	588 mm
Performance	5.1	Travelling speed		10.8/10.8 mph	17.4/17.4 km/h
	5.2	Lifting speed		96/133 fpm	0.49/0.68 m/s
	5.3	Lowering speed		80/83 fpm	0.41/0.42 m/s
	5.5	Drawbar pull		4810/2090 lbf	21400/9300 N
	5.7	Gradeability	%	20 / 20	
5.10	Service brake		mechanical / hydraulic		
Drive	7.1	Engine manufacturer / type		IMPCO K25	
	7.2	Engine power rating		60 hp	44 kW
	7.3	Rated speed		2700 rpm	
	7.4	Number of cylinders / engine displacement		4/152 in ³	4/2488 cm ³
Other	8.1	Travel control / transmission type		Torque converter	
	8.2	Working pressure for attachments		2320 psi	160 bar
	8.3	Oil flow for attachments		20 gpm	80 l/min

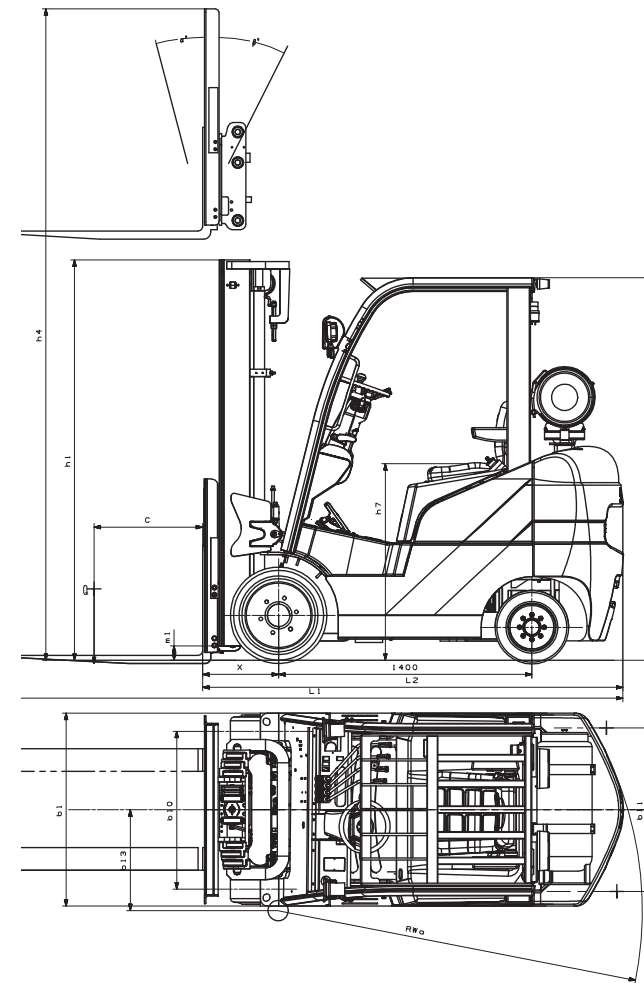

Performance

The IMPCO K25 engine with an IMPCO fuel system provides outstanding quality and performance and exceeds the standard for economy segment trucks. The timing chain driven camshaft ensures maximum durability while the innovative deceleration fuel shutoff maximizes energy efficiency.

Quality & Support

Baoli forklifts come with the KION NA Standard Warranty.
 1st Year: Standard Equipment/Unlimited Hours
 2nd Year: Standard Powertrain/4,000 Hours
 Extended warranty available

Service Network

Fully integrated into the KION North America supply chain and service system, Baoli provides shared resources from KION brands which offers a well-developed sales and service network. With Baoli spare parts in stock at the KION North America warehouse, spare parts delivery is possible within 24 hours throughout the U.S. by our authorized dealers.

Standard Equipment

- Cushion 21 x 7-15 drive and 16 x 6-10.5 steer tires
- 6° forward, 5° backwards tilt
- 83.3" high overhead guard
- Rear pillar assist handle with horn
- Three individual hydraulic control levers
- Three function valve and reeving
- Tilting, adjustable steering column
- Comfort suspension seat with orange seat belt
- Sequential seat belt interlock
- LED twin spotlights forward - OHG mounted
- Back-up alarm
- Amber warning light - OHG mounted
- Drop-down gas bottle bracket
- Standard KION Warranty



Comfort & Convenience

The KBG25C is equipped with many operator comfort and convenience features at no extra cost. The fully adjustable comfort suspension seat and tilt steering column provide a more comfortable ride while accommodating different operators. LED work lights and a rear pillar assist handle with horn are among the work assist features on this model.



Low Maintenance

- 500-hour maintenance interval
- Easily accessible components
- Engine hood opens to nearly 90°



Options

- Triplex mast 86" - 186" - 45"
- Simplex ("trucker's") mast - 63" - 81.5" - 0"
- 10° forward / 3° backward tilt
- 38" high load backrest
- Hang-on sidershifter
- Integrated sidershifter
- 4-function hydraulics
- Treaded or non-marking cushion tires
- Left and right external rear-view mirrors
- Internal panorama rearview mirror
- Blue spotlight rear - OHG mounted
- LED single spotlight rear - OHG mounted
- Road lights (brake, reverse, turn signals)
- Fire extinguisher
- Baoli safety orange paint

KION North America Corporation
 2450 West 5th North Street, Summerville, SC 29483
 Phone: 843 875 8000 Truck Sales Fax: 843 875 8471
 E-mail: trucksales.na@kiongroup.com
 www.kion-na.com

Standard truck meets all applicable mandatory requirements of ANSI/ITSDF B56.1 standards for powered industrial trucks. NOTE: Performance data may vary due to motor and system efficiency tolerances. The performance depicted represents nominal values obtained under typical operating conditions. Metric dimensions are in millimeters unless otherwise specified. All metric dimensions are not direct equivalents due to rounding data. The descriptions and specifications included on this data sheet were in effect at the time of printing. KION North America Corporation reserves the right to make improvements and changes in specification or design without notice and without incurring obligation. Please check with your authorized Baoli dealer for information on possible updates or revisions.