

Linde Material Handling

Linde

Progress in action.
Linde R 10C to R25 Active
Reach Trucks.





Normally it takes hard work to gain a head start.

With the Linde Active reach trucks, you are up front right away. The Linde Ergo Concept incorporated as standard makes work easier and appreciably more efficient at the same time. Every one of these reach truck models, from the compact R 10 C to the



heavy-duty R25, unites exquisite functionality and advanced ergonomics. Backed by technology that smoothly raises productivity of your warehouse operations to a level you never thought possible.





The compact, individually adjustable steering wheel is directly integrated in the control console. All models are equipped with the proven Linde twin drive pedals and Linde Load Control joysticks.



The high-comfort seat fitted with a variable lumbar support has been specially designed for the sideways seating position in reach trucks.

Tailored to the operator. The Linde Ergo Concept.

Comfortable seat, easy operation, clear visibility in every direction—the operator compartment is a true comfort zone where motivation to perform at the top level comes naturally.

Fitted as standard with an electrically adjustable lumbar support, the high-class seat adapts comfortably to the operator's anatomy and can be adjusted for both sitting angle and height (150 mm vertical range). All load handling functions are controlled by the Linde Load Control joysticks. Effortless fingertip actuation moves the forks and load with smooth hydraulic power.

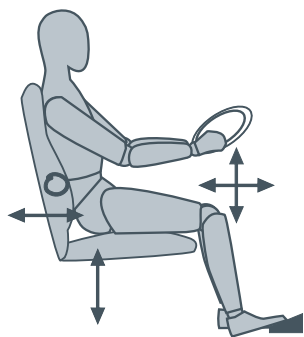

Patented Linde Rheological Steering (LRS), with the option of 180° or 360° steering, can be set to the operator's preferred manner of working. Variable steering resistance gives the reassuring feeling of maintaining perfect control of the truck in every situation while truck status is continuously monitored on an informative digital display. At a glance the operator can check steering angle, battery state, operating hours, motor temperature, brakes or servicing due.

**Efficient working without stress.
High productivity is a standard feature
of Linde Active reach trucks.**

Linde Active reach trucks.
The active contribution to warehouse productivity.

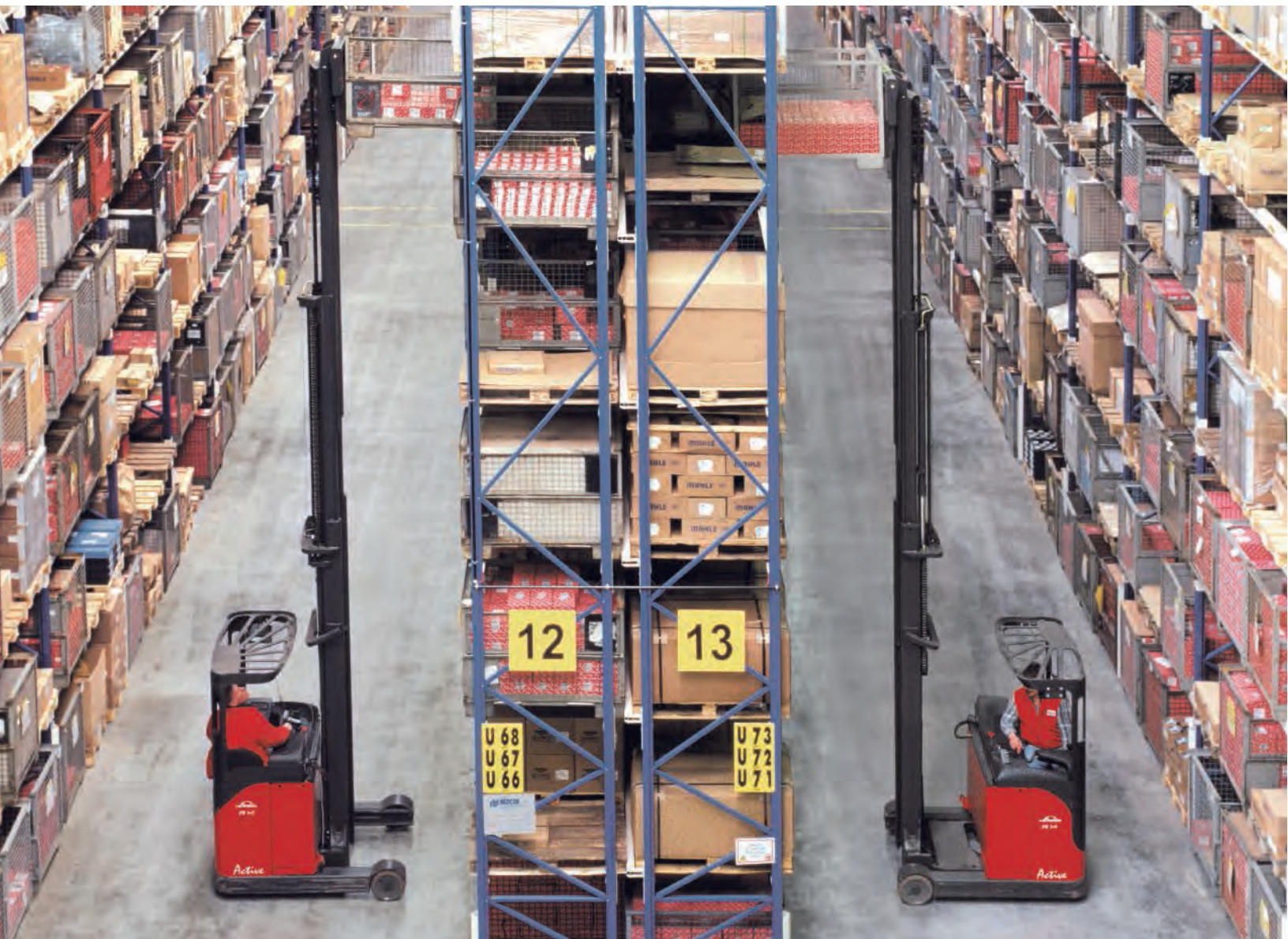



At Linde, high productivity does not come with a high price tag. Nor do you have to wait long to see the results. Our answer to more exacting demands in goods handling is innovative truck concepts embodying high efficiency and high economy.

The newest example is the Linde Active S - Version reach trucks. Their maintenance-free AC motors bring you a sizable gain in power – up to 10% more than customary shunt-wound motors. An investment in cutting-edge technology that is also a valuable investment in your business success.

Quality and innovation have always been, and will remain, the driving force behind growth at Linde. When all is said and done, our aim is to offer our customers a genuine competitive advantage along with superior technology.

Cutting-edge technology leads to a competitive edge. The performance potential of Linde Active reach trucks enjoys the highest recognition among users.



Progressive technology – enhanced performance.

Every Linde Active reach truck's potential for performance is huge. How you use it is entirely up to you. With this advanced truck technology all your options are open.

Controlled acceleration, smooth maneuvering, responsive braking. Linde Digital Control (LDC) is active for all travel, reach and hydraulic functions. All parameters are individually programmable to suit the specific task. As in modern-day automobiles, the electronics are totally enclosed for protection from dust and moisture to ensure reliable, troublefree operation. CAN bus connection streamlines truck diagnosis and servicing.

Utmost working safety is provided by three independent braking systems: Hydraulic drum brakes, regenerative braking on releasing the drive pedal (Linde Brake Control) and countercurrent braking when changing between forward and reverse travel.

State-of-the-art engineering, low operating costs. Smart control systems bring greater efficiency and economy to routine work.



Efficient conversion of energy to motion. Linde Digital Control with CAN bus connection.

Visibility in every direction. The Linde Active mast concept.

Linde truck masts are designed for full visibility throughout the load handling cycle. Compact design and high residual capacity result in safety of the first order – at heights up to 11.5 metres. Mast sections are nested and move smoothly and quietly over their full extension to automatically cushioned maximum height position.

Linde Active reach trucks of 1,400, 1,600 and 2,000 kg capacity are standard equipped with a sturdy triplex fixed mast operating with only two lift jacks. Integral sideshift with hydraulic fork tilt is also provided.

The smaller R 10 C to R 14 C models have compact tilting masts of standard, duplex and triplex type (R 10 C – R 12 C) with optional sideshift.

In this respect the R 25 is unique with its dedicated heavy-duty mast capable of lifting loads of 2,500 kg.

Profitability in clear view.
Tall orders are no problem for the Linde
Active mast concept.







Linde
R16



Active

Linde

Active

Cold store specialists.

Cold storage warehouses are one of the toughest working environments for both man and machine. Linde Active reach trucks have no trouble coping with such severe conditions. Inside the fully integrated cold store cab the operator can get on with the job in warm and spacious comfort. There is no need to wear a cumbersome cold store suit or take regular, time-wasting "warm-up" breaks outside the store.

Temperature inside the cold store cab can be regulated to any desired comfort level between 10° C and 22° C. It stays constant at the set level regardless of whether the truck remains inside the cold store all the time or travels in and out.

Visibility is good on all sides, almost as good as with the regular truck version due to the generously sized windows (optionally heated). Altogether, the Linde cold store cab can increase productivity as much as 40%.

Versatility is the one of the strengths of Linde Active reach trucks. They deliver top performance in regular or extreme conditions.

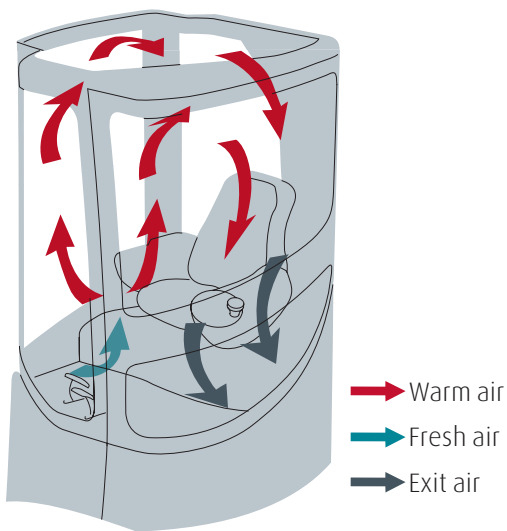

Pleasantly warm and no drafts. Despite continuous air change, temperature inside the cab stays constant at the set level.

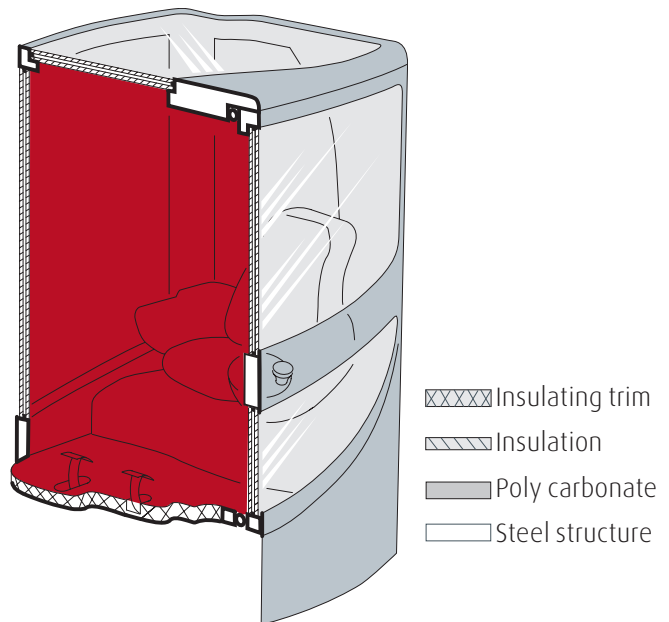

Double insulation, non-reflecting materials, intercom: Extra comfort adds up to greater productivity.

Doubly efficient.

Double-deep reach trucks are a specialized version within the Linde Active line of models. They have telescopic forks that easily reach pallets stacked in the rear slot of double-deep racking. Not only do these trucks improve productivity in storage and retrieval operations; they also make possible more economical utilization of warehouse space.

Linde Active double-deep reach trucks are built for load capacities of 1,400 to 2,000 kg. They are true multi-purpose units, designed with the flexibility to efficiently service both the standard single and double-deep type of racking.

An option that puts extra warehouse economy in easy reach. Linde Active double-deep trucks with telescopic forks uncover potential that lies beyond other trucks.

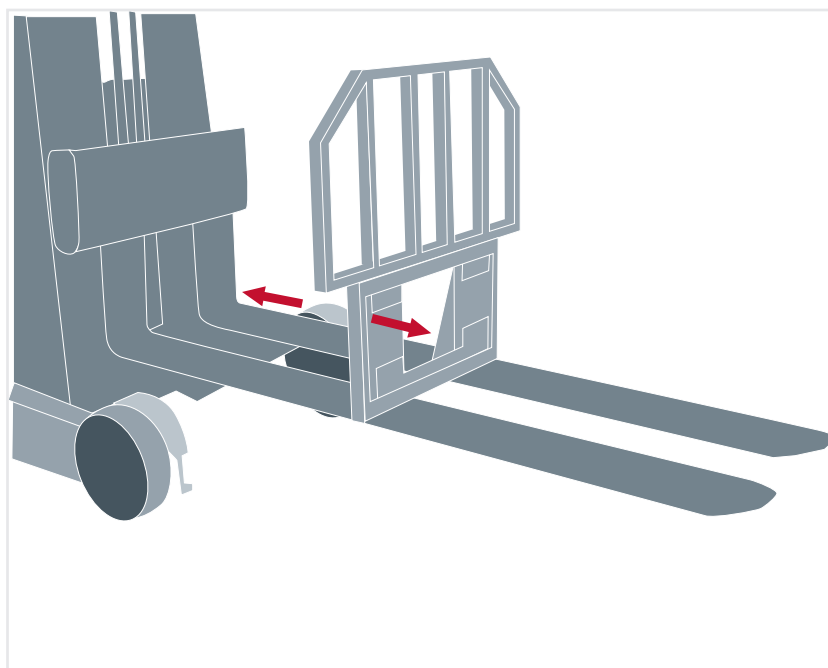

Every bit of space is valuable in a goods warehouse. Linde helps you to increase storage capacity in the same space without any structural additions. Double-deep storage means that fewer aisles are needed between racks, leaving more space available for storage locations.

Linde Active double-deep reach trucks feature all the benefits of the standard truck version. Only they have an extended scope of application. Their exceptional flexibility opens up potential vital to ensuring a high level of efficiency in logistics operations.

**New potential for profitability.
Double-deep storage maximizes
warehouse space productivity.**

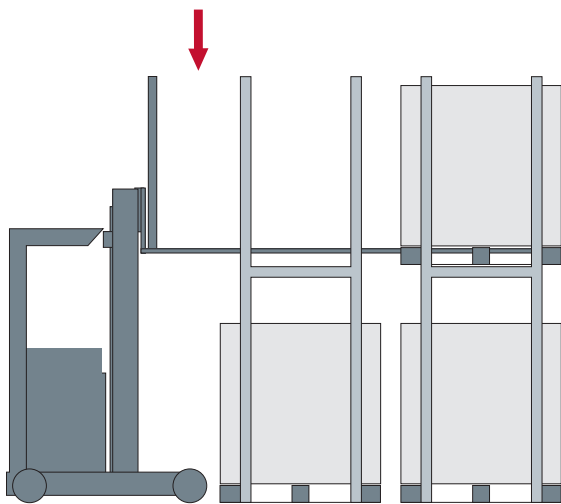

Fewer aisles, more storage capacity. Linde Active double-deep reach trucks make more of your available warehouse space.

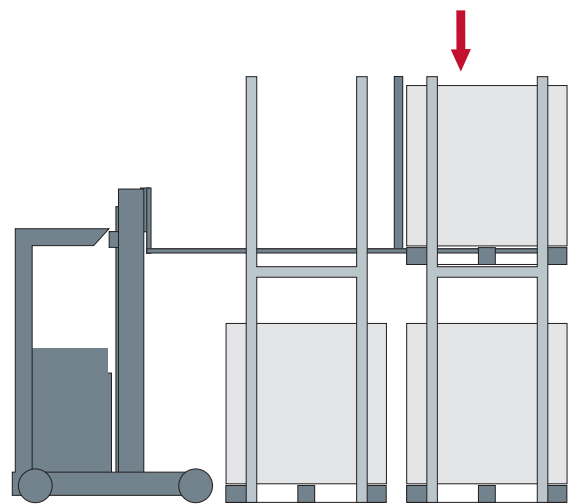

Robustness and stability of the truck chassis come fully into play when the telescopic forks reach out to double-deep position.

Options for all your needs.



Linde Load Control using four separate levers. The alternative to the two standard four-way joysticks.

Modern warehouse management systems make extensive use of mobile terminals for direct data communication between PC workstation and trucks.

Single drive pedal makes the shift to Linde easier for operators accustomed to driving trucks with conventional pedal layout.

Lift preselector aids quick and accurate load storage and retrieval at large heights. Can be programmed for 99 rack levels.

Log-on keypad restricts truck access to authorized operators. A valid ID code must be entered before the truck can be started and operated.

Lift height indicator. During storage and retrieval, exact height of the forks is indicated on a digital LED.

Mobile barcode reader for efficient data transmission to the warehouse management system.

Closed-circuit TV. Practical solution for high-bay warehouses. Gives the operator a clear view of forks and loads during storage, retrieval and stock-taking.

Comprehensive options to answer every warehouse handling need.

Continuous availability.



Durable equipment, long maintenance intervals, rapid service when needed. Quality from start to finish reflects in your bottom line.

Maximum uptime isn't just a question of quality of the truck itself. It is also the result of uncompromising quality in service. Qualified advice, factory-trained service technicians and a dense network of dealers and service centers provide you with the high level of assurance and technical independence vital to keeping your business running smoothly.



Battery check or replacement is completed in next to no time. The battery can be moved forward using the mast reach function or changed from the side.

Linde's rich expertise in warehouse trucks puts it in the position to knowledgeably fulfill the complex requirements of modern warehouse logistics. And to turn many decades of material handling truck experience into direct benefits for users of the equipment.



Model R 10 C, R 12 C and R 14 C

Series 115-02

Capacity 1.0; 1.2 and 1.4t

Mast Fixed

Features **C for compact size**
The economical solution for handling light load weights at medium heights of lift and in narrower working aisles. These compact models can optionally be equipped with tilting standard or duplex masts, the R 10 C and R 12 C also with tilting triplex masts.

1,000 to 2,500 kg capacity.

Linde Active reach trucks grow with the task.

From the compact models of the C - Series to the heavy-duty sizes of 2,500 kg capacity, all Linde Active reach trucks share the same high standard. Chassis, operator compartment, comfort-class seat, operating controls and drive are identical throughout the range.



R 16 N and R 20 N

R 14, R16 and R 20

R 25

115-02

115-02

115-02

1.6 and 2.0t

1.4; 1.6 and 2.0t

2.5t

Fixed

Fixed

Fixed

N for narrow chassis

Measuring only 1,080 mm wide overall, these narrow versions can easily enter drive-in racking and effortlessly maneuver in block stacking warehouses. They can lift up to a height of 9.5 metres.

Premium class

Lifting to a height of 11.5 metres, these models are the first choice for high-bay warehouses. They are equipped as standard with a clear-view fixed triplex mast, tilting fork carriage and integral sideshift. Highest residual capacities are available with the heavy-duty R 14 HD and R 16 HD.

Heavyweight

Designed to handle extra heavy loads, the R 25 has a dedicated heavy-duty mast that can be fitted with extending forks for double-deep storage when required.



With annual sales exceeding 100,000 forklift trucks, Linde ranks among the world's leading manufacturers. This position has been justly earned. Linde trucks excel not only with their recognized innovative technology but especially due to their low energy and operating costs.

High quality in production is matched by the standard of the service we provide. With our ten manufacturing plants and a comprehensive network of local partners, we are at your call around the clock and around the world.

Your local Linde dealer offers a complete single-source package including qualified pre-sales consulting, after-sales service and flexible finance options—whether leasing, renting or purchasing.

Linde Material Handling



For more information on Linde material handling equipment, please contact:

KION North America Corporation
2450 West 5th North Street, Summerville, SC 29483
Phone: (843) 875-8000 Truck Sales Fax: (843) 875-8471
E-mail: trucksales.na@kiongroup.com
www.kion-na.com